

Mistral

**Samrey Generators
& Turbines Ltd**

Web: www.samrey.co.uk
Email: info@samrey.co.uk

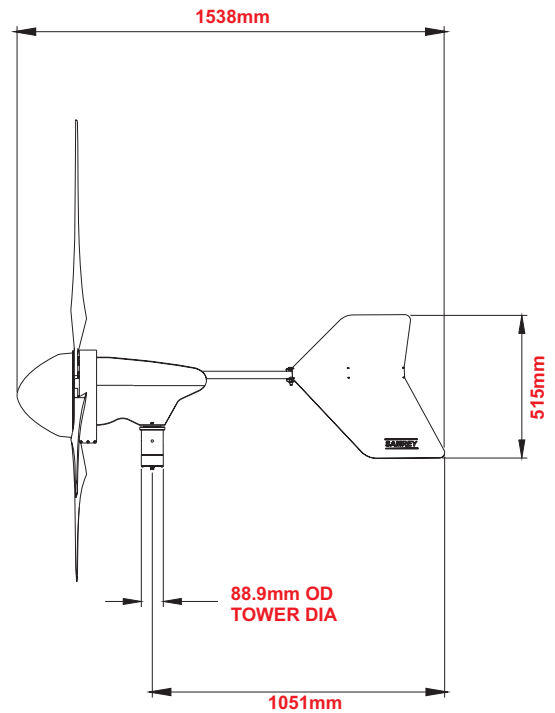
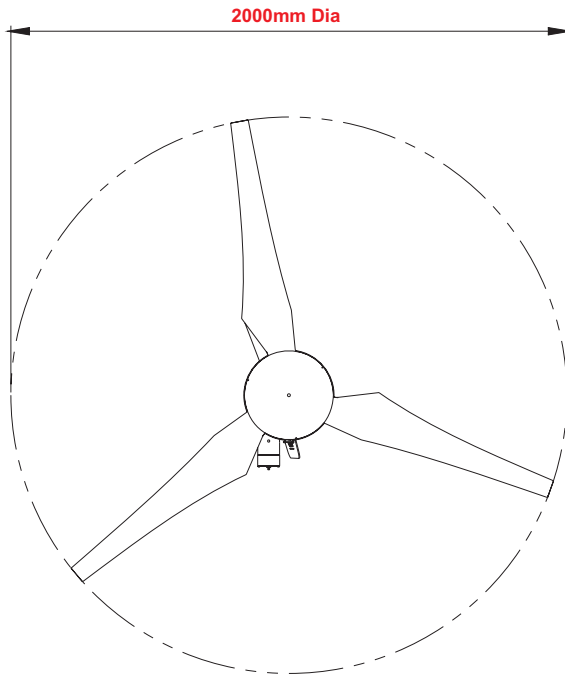

Rotor Diameter:	2.0 metre (78.7")
Rated Wind Velocity:	8m/s (17.8mph)
Rated Output:	300 watts
12m/s Output:	850 watts
Maximum Output:	1150 watts
Rated rpm:	390 RPM
Cut-in:	3m/s
Weight:	20kg
Output Voltage:	120VAC 3-Phase Transformed to 24V or 48V
Tower Mount:	88.9mm (3.5")
Warranty:	2 years (limited)

- Only three moving parts & sealed for life bearings
- Proprietary 3-phase axial PMA utilising Neodymium Iron Boron technology
- Tilt-rotor furling system gives high wind protection
- Variable furling speed
- Quiet operation with low TSR rotor
- Excellent performance at truly **low** wind speeds
- Low visual impact design & sleek appearance
- Innovative blade with unique aerodynamic design.
- High-Voltage AC power transmission (thereby reducing the cost and power loss of cable runs)
- Controller unit converts power to low voltage DC
- Heavy duty and rugged construction
- CNC machined components throughout
- Guyed and freestanding towers available
- Ideal for grid-tie or off-grid battery charging
- Designed, developed and manufactured in the UK

Predicted Energy Production:

The instantaneous power curve shown here is based upon real world measurements. Every turbine installation is unique and the energy production may deviate from figures listed here due to many factors such as turbulence and wind shadowing. Particular sites for small wind turbine installations should be evaluated on their merits. If in doubt, seek the advice of an expert. The Annual Energy Production graph uses mathematical statistical tools to predict windspeeds and turbine energy production. This graph is for use as an indicator only as actual performance may vary due to local environmental considerations. A Weibull distribution 'K' Factor of 2 has been used in the calculations.

Instantaneous Power Curve

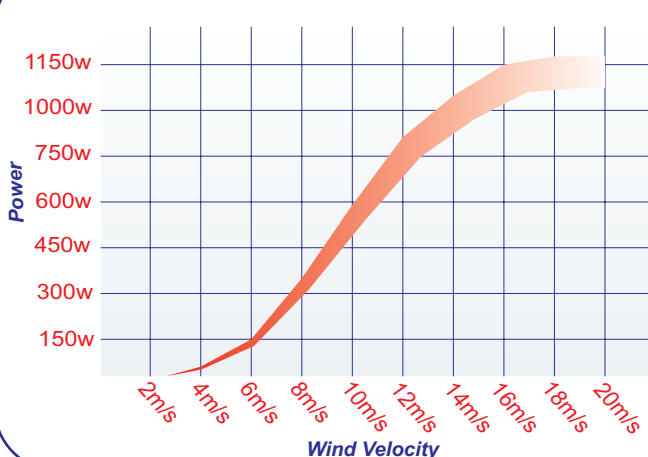

Annual Energy Production

